

2B1 Line Adapter

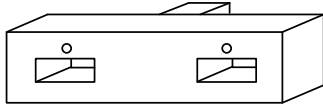

BT socket

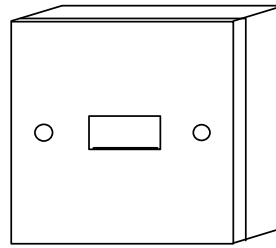

2 Lift Application

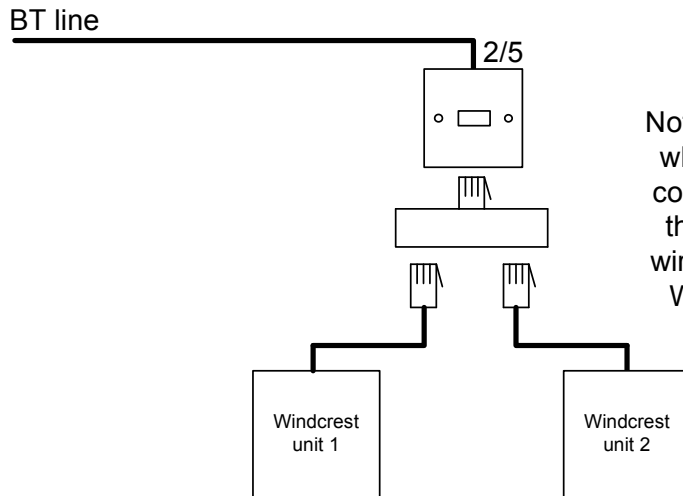

Note: If the LEDs are not lighting up when a phone (or speaker unit) is connected and online then reverse the wires in the BT socket. (RED wire to the place of the WHITE and WHITE to the place of the RED)

3 Lift Application

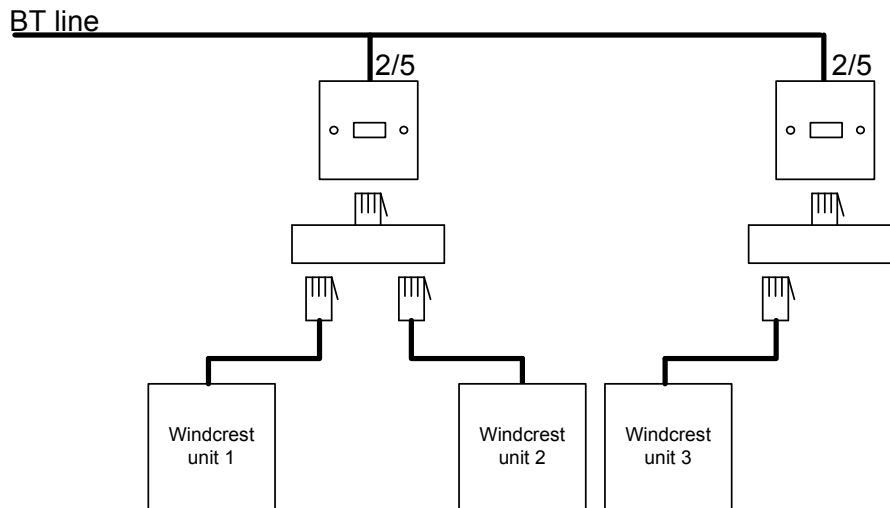

Note: Must use this 2nd adaptor for the 3rd unit so that the voltage drop for all Windcrest units is equal.

Drawing for Double Telephone Adapter (2B1) connections

Drawing No: 2b1 Issue No:1 Date:27/09/05

Windcrest

Tel: 0208 795 0333
Fax: 0208 795 0444