

**AVCOM EN-4RD SCH System**  
**With Evacuation &**  
**Fire Fighting Intercom**  
**Installation Instructions**

|                   |  |   |   |
|-------------------|--|---|---|
| Cable description |  Multi core wire |  CAT5 |  Cable used in special cases only |
|-------------------|--|---|---|

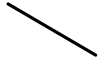
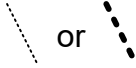
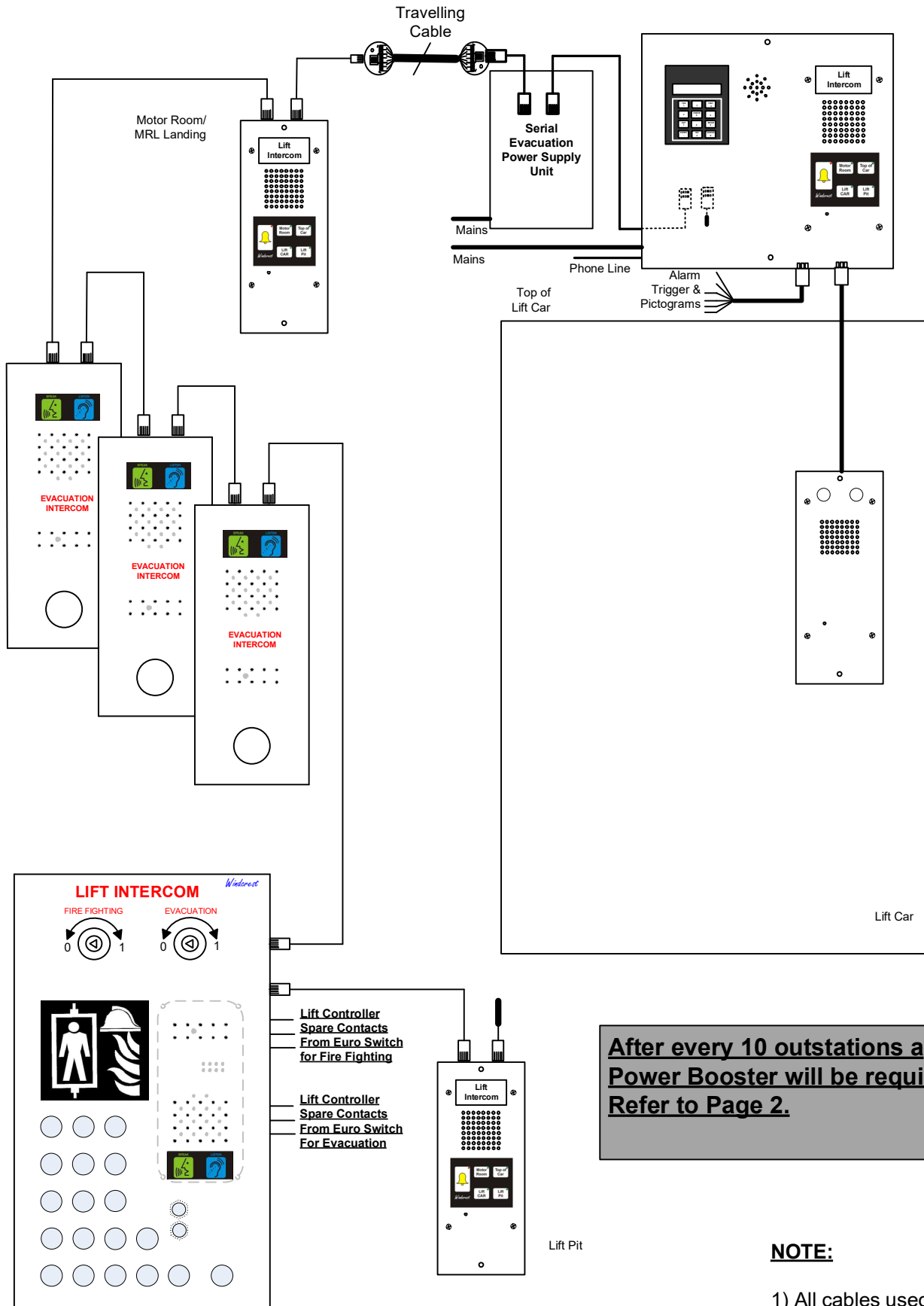

**After every 10 outstations a Power Booster will be required. Refer to Page 2.**

**NOTE:**

1) All cables used for the system must be Min CAT5

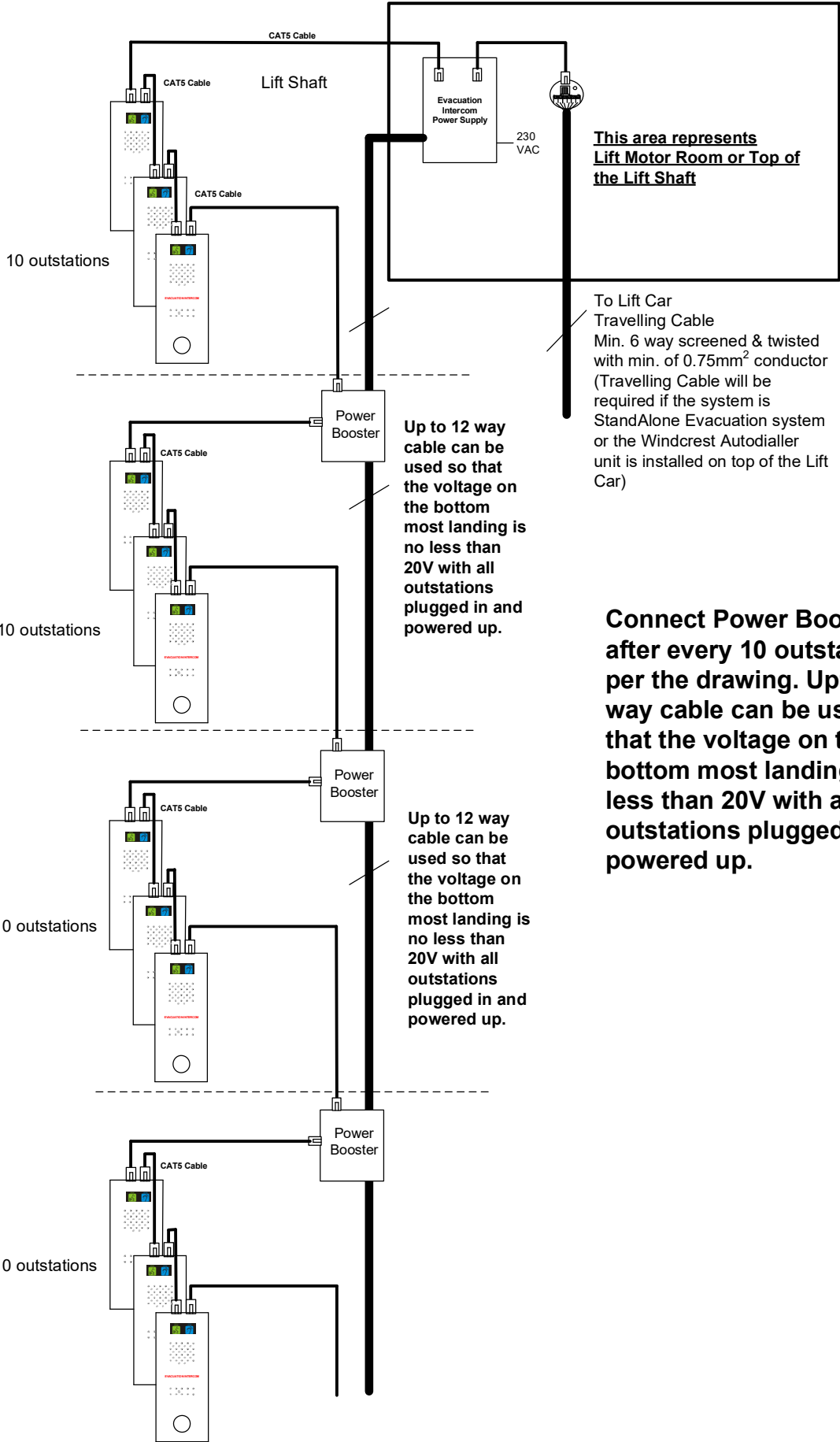

**Connect Power Booster after every 10 outstations as per the drawing. Upto 12 way cable can be used so that the voltage on the bottom most landing is no less than 20V with all outstations plugged in and powered up.**

**Power Booster Wiring**

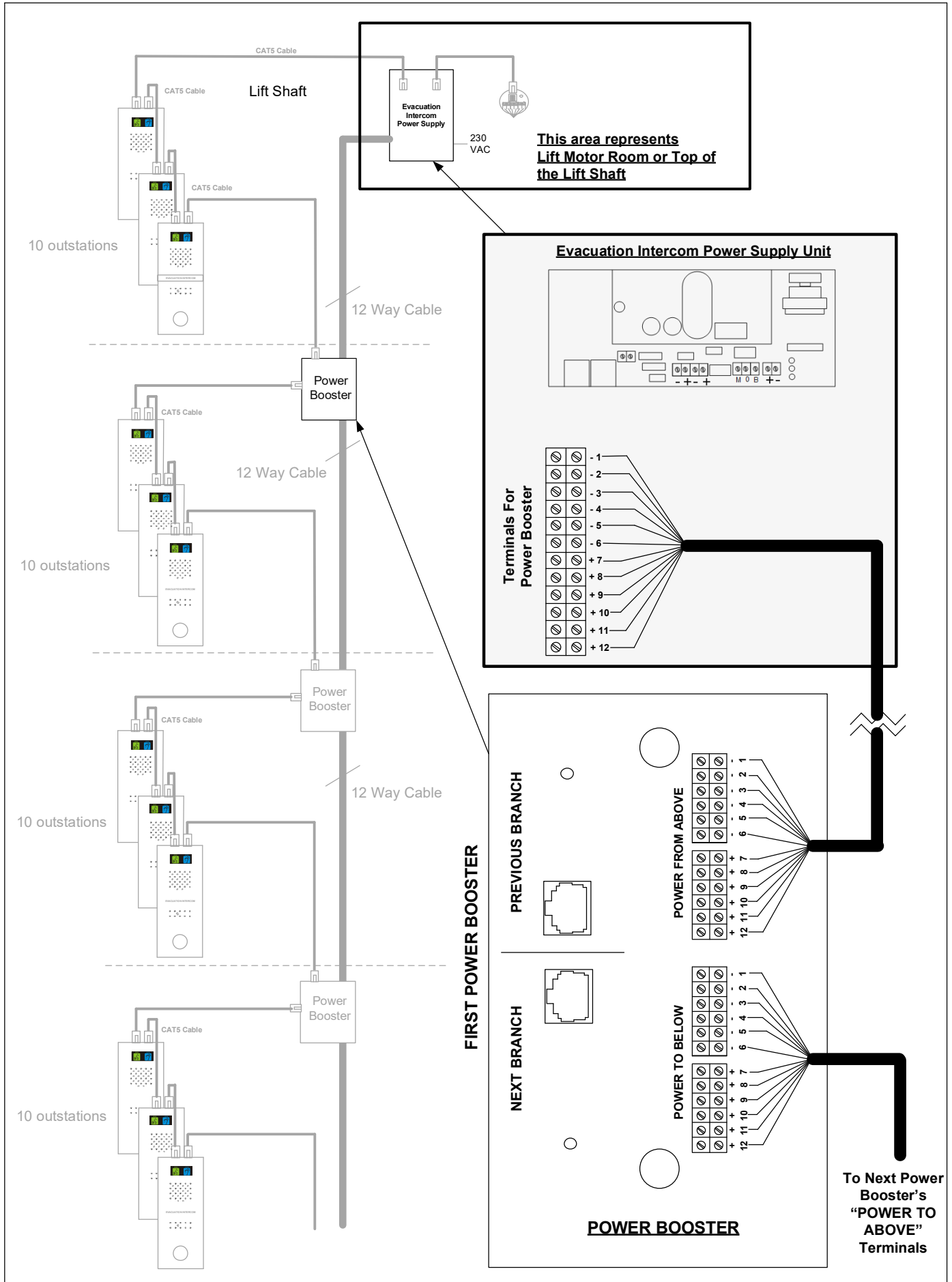

**PSU to Power Booster Wiring**

Drawing: PSUtoBooster 03/01/2023  
*Windcrest* (UK) Ltd

Tel: 0208 795 0333  
 Fax: 0208 795 0444  
 Page 3

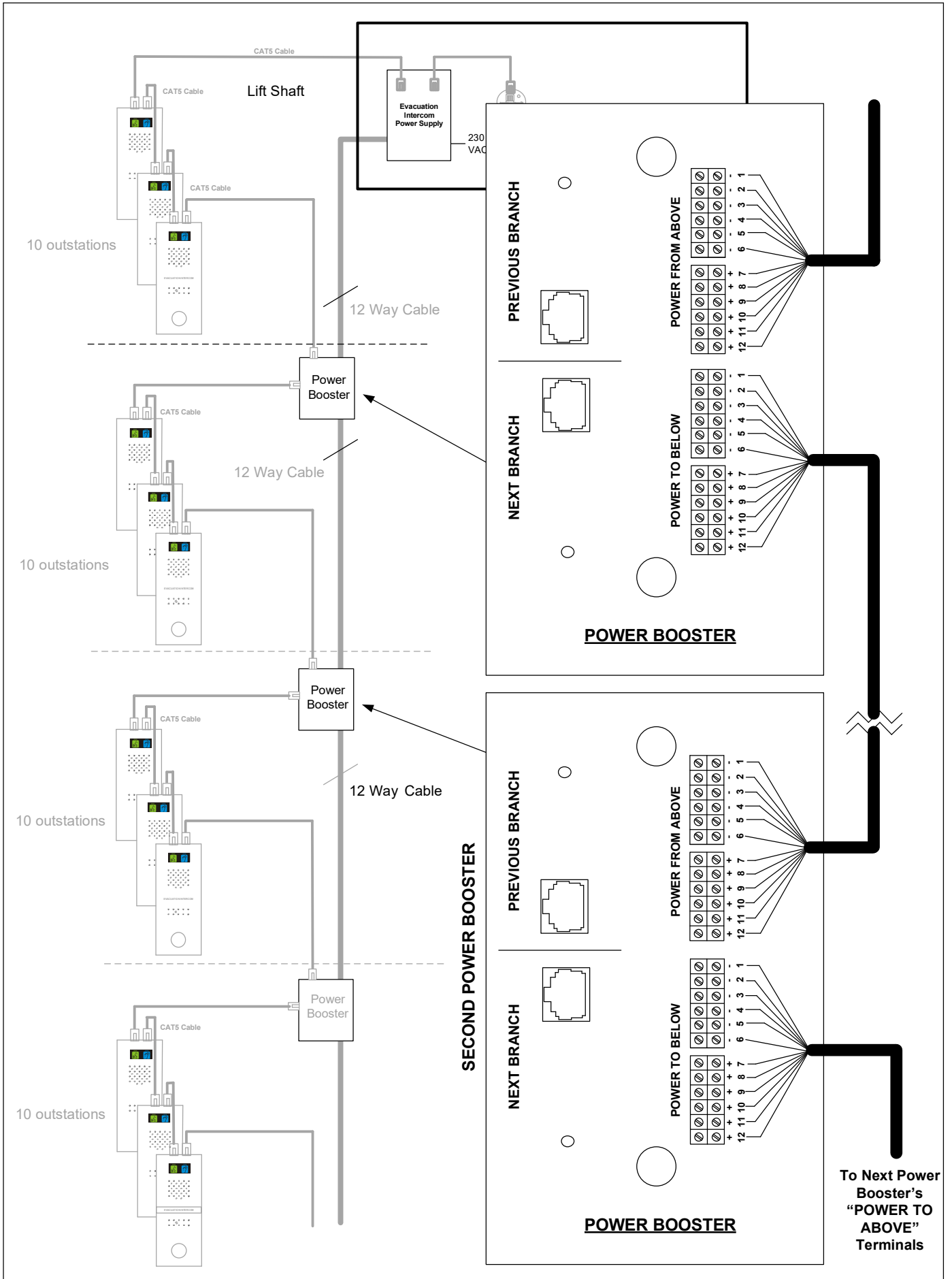

# Power Booster to Power Booster Wiring

Drawing: Booster-Booster 03/01/2023  
*Winderest (UK) Ltd*

Tel: 0208 795 0333  
 Fax: 0208 795 0444

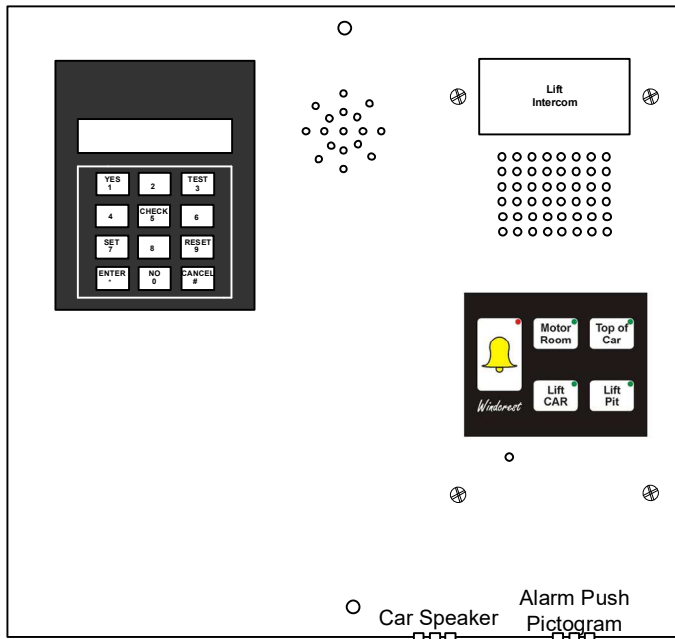

Green Pictogram  
Contacts  
Normally Open  
**White & Green**

Yellow Pictogram  
Contacts  
Normally Open  
**Yellow & Blue**

Alarm Push  
Contacts for Lift  
Car COP  
(Voltage Free  
Contacts) –  
**Pink & Gray**

Top of Car

The unit will work out Normally Open/Close Push contacts automatically on power up. Connect Alarm Push wires to the unit prior to powering it up.

Speaker box behind COP

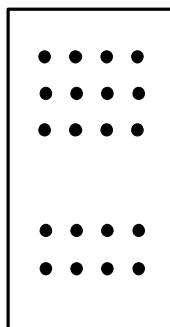

**Note: For best performance the Windcrest standard speaker box assembly should be used with Windcrest designed faceplate or same grill configuration on COP.**

**If the holes for the speaker are restricted without a back box and microphone not positioned to allow sound to enter it the system will not perform correctly.**

Lift Car

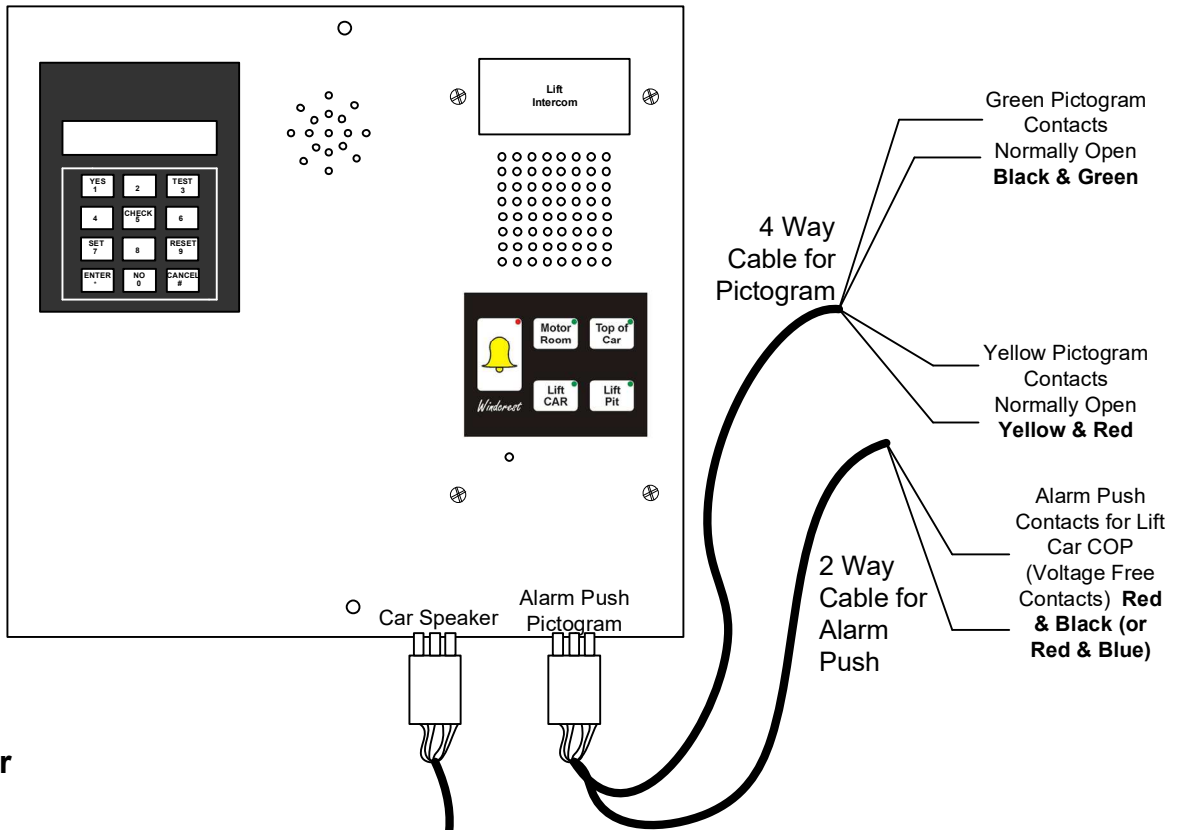

Top of Car

The unit will work out Normally Open/Close Push contacts automatically on power up. Connect Alarm Push wires to the unit prior to powering it up.

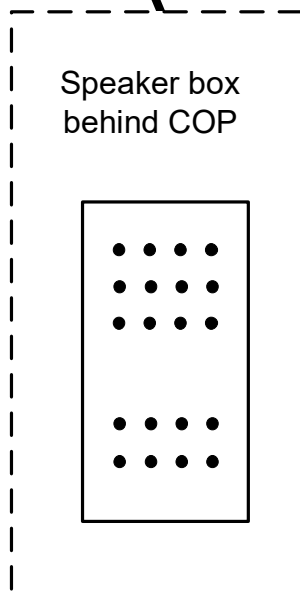

**Note:** For best performance the Windcrest standard speaker box assembly should be used with Windcrest designed faceplate or same grill configuration on COP.

If the holes for the speaker are restricted without a back box and microphone not positioned to allow sound to enter it the system will not perform correctly.

Lift Car

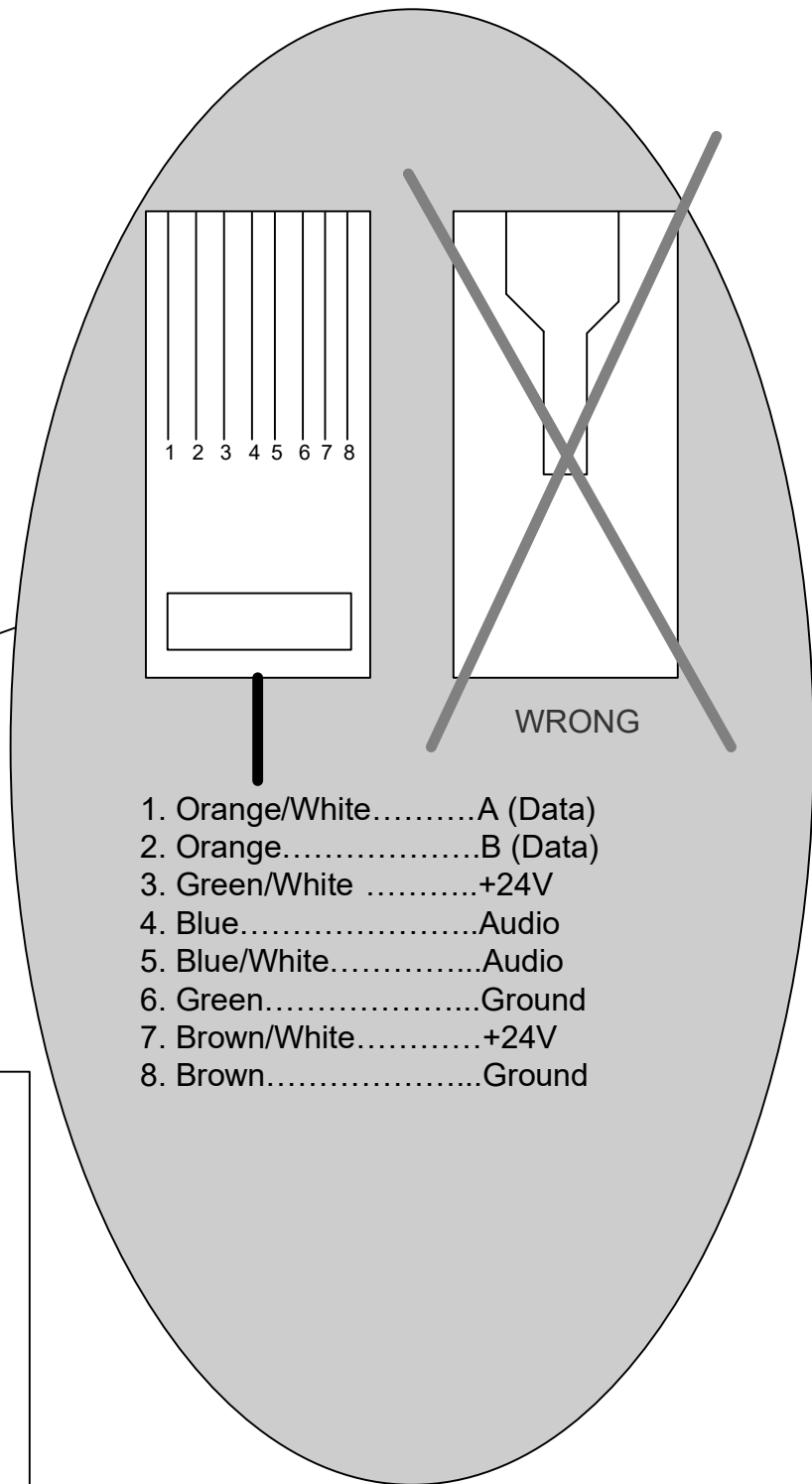
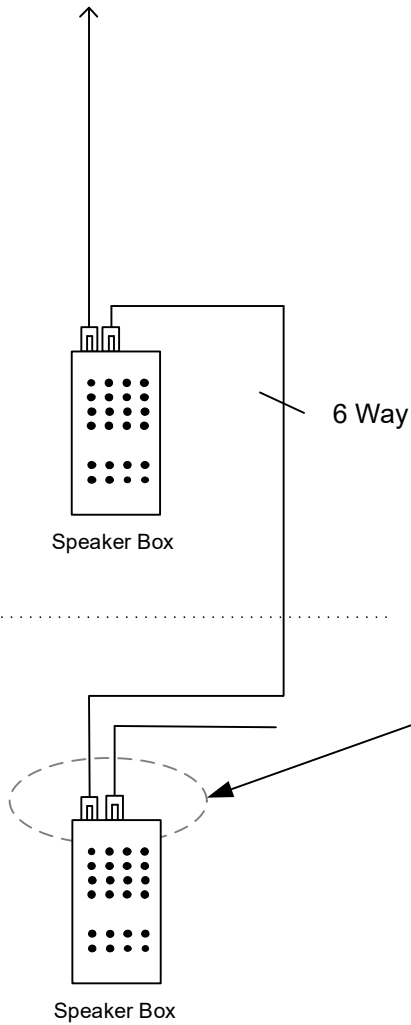

1. Orange/White.....A (Data)
2. Orange.....B (Data)
3. Green/White .....+24V
4. Blue.....Audio
5. Blue/White.....Audio
6. Green.....Ground
7. Brown/White.....+24V
8. Brown.....Ground

**RJ45 to Terminal**

A = White  
 B = Green  
 + = Pink  
 GND = Gray  
 BT (Audio) = Blue  
 BT (Audio) = Yellow

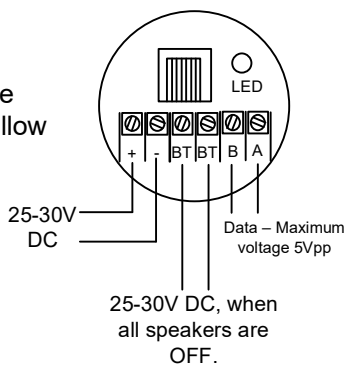

For Troubleshooting, connect the RJ45 to Terminal to the Cable and check the above readings. If the readings are different than above, please contact Windcrest.



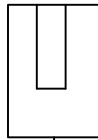

Connect bus terminator  
to the last outstation on  
each bus.

**Note: The Terminator must be installed. If the terminator is not installed it will result in un-reliable operation of the system due to data corruption.**

**RJ 45 Bus Terminator &  
Speaker Box**

**Drawing: Terminator**

**Page: 8**

*Windcrest* LiftBits Ltd Tel: 0208 795 0333  
Fax: 0208 795 0444

# AVCOM Functions

## Configuration

The AVCOM system can be configured to be EN1/EN3/EN4 System.

## Interconnection

All the speaker box assemblies will be connected directly or indirectly via a 6 wire bus (however a CAT5 cable with RJ45 Connectors will be used of installation) to the Control/Power supply unit. This interconnecting wire bus will have a 2 pairs of wires for the Power supply, a pair for the Audio and a pair for the Data.

## Operation

### **Autodialler**

The Autodialler will function at all times when the Fire Fighting Switch has not been operated. If the Car push button is operated, for 3 seconds and the alarm filter allows the signal to trigger the Windcrest autodialler, the Yellow Pictogram will operate and a Speech Synthesis message will be announced in the lift car. This message will instruct and reassure the passenger that a call for assistance is being made.

The autodialler will attempt calling the 1<sup>st</sup> pre-programmed number. If the person who answers the call, presses \* button on the telephone handset, Green Pictogram will operate in the Lift Car. During the conversation a speech synthesis reminder will occur to inform the need to press the Alarm Button in the Lift Car to continue the call. If he fails to do so, the call will terminate. If however the call is to be terminated prior to the automated termination, a "0" on the called persons telephone will terminate the call.

The calling out by the Engineer from the Top of car, Motor Room and the Lift Pit will be the same, except the pictogram operation. Lift Car Alarm Push will have priority over all other Alarm Calls. i.e. If Alarm is Activated from top of car and during the call, if Alarm Push button is detected from the Lift Car, it will disable the Top Of Car call and activate Alarm call from Lift Car.

### **Intercom**

If unit is programmed for EN4 functions, at any time when the system is idle, i.e no alarm activation/Fire Fighting OFF, intercom facility will be available within Motor Room, Lift Car, Lift Pit, Lift Top Of car. Intercom can be operated by pressing the corresponding button on the KeyPad. Pressing the same button will switch off the intercom. When Intercom will be open corresponding LEDs will be ON, on the keypad on all outstations to indicate Intercom is ON.

Note : Anytime, if Alarm button is pressed intercom will be switched off and AVCOM system will perform normal Autodialler function from the outstation.

# AVCOM Evacuation Functions

## Lift Controller Spare Contacts:-

Blue - Common

Green - Normally Open

Yellow- Normally Closed

## Interconnection

Connect the main Evacuation Panel to the Bus. Connect all the Landing Speakers to the bus. This interconnecting wire bus will have a 2 pairs of wires for the Power supply, a pair for the Audio and a pair for the Data. Yellow & Blue from Evacuation Panel must be connected AVCOM unit's Fire Evac Cable's Yellow Blue. Refer to Lift Controller & Evacuation Switch wiring.

## Operation

To activate the evacuation system, place the EURO switch in the ON position. All the LEDs for the Landing Speakers and the Lift Car will flash for 5 seconds when the system is analysing the Outstations. After 5 seconds, the LEDs on the main Panel will be ON for the outstations which are present working (i.e. Data Link is Working) for 3 seconds. All LEDs will be switched OFF on the Pit, Top Of Car, MRL Speaker Keypads. The "Listen" Pictogram will be ON to indicate that the system is ready.

At the all Landing Speakers Call Button will Flash slowly to Indicate System is ON. On pressing the CALL button on any outstation, the LED will start flashing faster to indicate placement of a call. At the same time the corresponding LED for that outstation and a buzzer will operate. The flashing and buzzing will continue till the person on the Main Control Panel answers the call by pressing the corresponding button. At the point the voice link is opened, the LED on the calling outstation and main panel will remain ON till the voice link is terminated.

When Voice Link is active, press to speak button will control the speech from the master station. When press to speak button is released, Main Control Panel's microphone will be muted and outstation microphone will be ON, and Main Control Panel's microphone is muted. When press to speak button is pressed and Hold, Outstation microphone will be muted and Master Panel microphone will be ON. Pictograms at the Main Control Panel and the Landing Speaker will show the status of speak/listen. i.e. when the speaker box's Mic will be ON, "Speak" Pictogram will illuminate and when the Speaker Box's Mic will be OFF, "Listen" Pictogram will illuminate.

A call can be made to any of the Outstation by simply pressing the button for that outstation on the Main Control Panel. As soon as the button is pressed the LED on both the outstation and the Master Panel will be steady ON and a two way communication is possible via press to speak button on the Main Control Panel.

The call can be terminated by the pressing the same button again at which point LEDs on the outstation and Main Control Panel will go off and the Pictograms at the Landing Speakers will be switched off and at the Main Panel "Listen" Pictogram will illuminate to indicate the system status.

When Evacuation Switch is turned OFF, Both the Pictograms at the Main Control Panel will be switched off and Push Button LED at all the Landing Speakers will be turned OFF. Top of Car, Pit, MRL speaker units' keypad will be live again.

**Evacuation System**

**Operation**

**Drawing : AVCOM Evac Functions Page: 10**

*Winderest* LiftBits Ltd Tel: 0208 795 0333  
Fax: 0208 795 0444

# AVCOM Fire Fighting Functions

## Configuration

The AVCOM system can be configured to be EN1/EN3/EN4 and/or with Fire Fighting System.

## Lift Controller Spare Contacts on the Fire Fighting Switch:-

Orange - Common  
White- Normally Open  
Yellow- Normally Closed

## Operation

When Fire Fighting Switch is turned on at the Fire Fighting Main Panel, 3 way communication will be turned ON among the Lift Car Speaker, MRL FF Landing Speaker/Top Landing Speaker and the Main Landing Speaker. There is press to speak push button at the MRL FF Landing Speaker/Top Landing Speaker and the Main Landing Speaker. When the Fire Fighting Switch is Turned ON, Green Pictogram will illuminate in the Lift Car to Indicate communication link is ON. Pictograms at the MRL FF Landing Speaker/Top Landing Speaker and the Main Landing Speaker to indicate the status of the system.

When the Fire Fighting system is ON, no other operation will be allowed.

Turning OFF the Fire Fighting Switch will switch OFF the Communication and Pictograms.

## Note:-

**If the stripped down Speaker & Mic are used in the Lift Car ensure the Microphone is securely placed to prevent water damage (For IPX3 Rating) .**

## **Background Operation**

The system will make the automated 3 day test calls to a Central Station in accordance to EN81-28.

## **Troubleshooting**

If LEDs on the Keypad of the outstation speakers, both pictograms in the Lift Car starts flashing continuously, it indicates data failure to that point. i.e. If Lift car speaker's both pictogram flash continuously, it indicates data link failure to Lift car speaker.

If Pictograms at the Main Fire Fighting Landing and the MRL-FF Landing/Top Landing Speaker for Fire Fighting start flashing continuously, it indicates data link is failed at those outstations. This can occur due to data cable failure or incorrect programming. i.e. if system is NOT programmed for Fire Fighting, FF Main Landing and Top Landing Speaker will not receive the Data.

On the Top of Car, MRL/Motor Room, Pit Speaker, there is a keypad representing all the buttons for Top of Car, Car, Pit and MRL/Motor Room. In the idle mode, those all LEDs will be lighting up in the loop to indicate system is live and Data Link is available to the speaker. If any of the button's LED does not light up in the sequence, it indicates that Outstation Speaker is not programmed in the system or that Outstation Speaker is not present in the system, which may be due to data failure to the outstation, Outstation Speaker not connected to the system or Outstation Speaker itself may have gone faulty.

Note: During the programming of the unit via Keypad, Unit will not scan any outstations. i.e. no data link, which will result in the flashing of the all the LEDs at all outstation speakers.

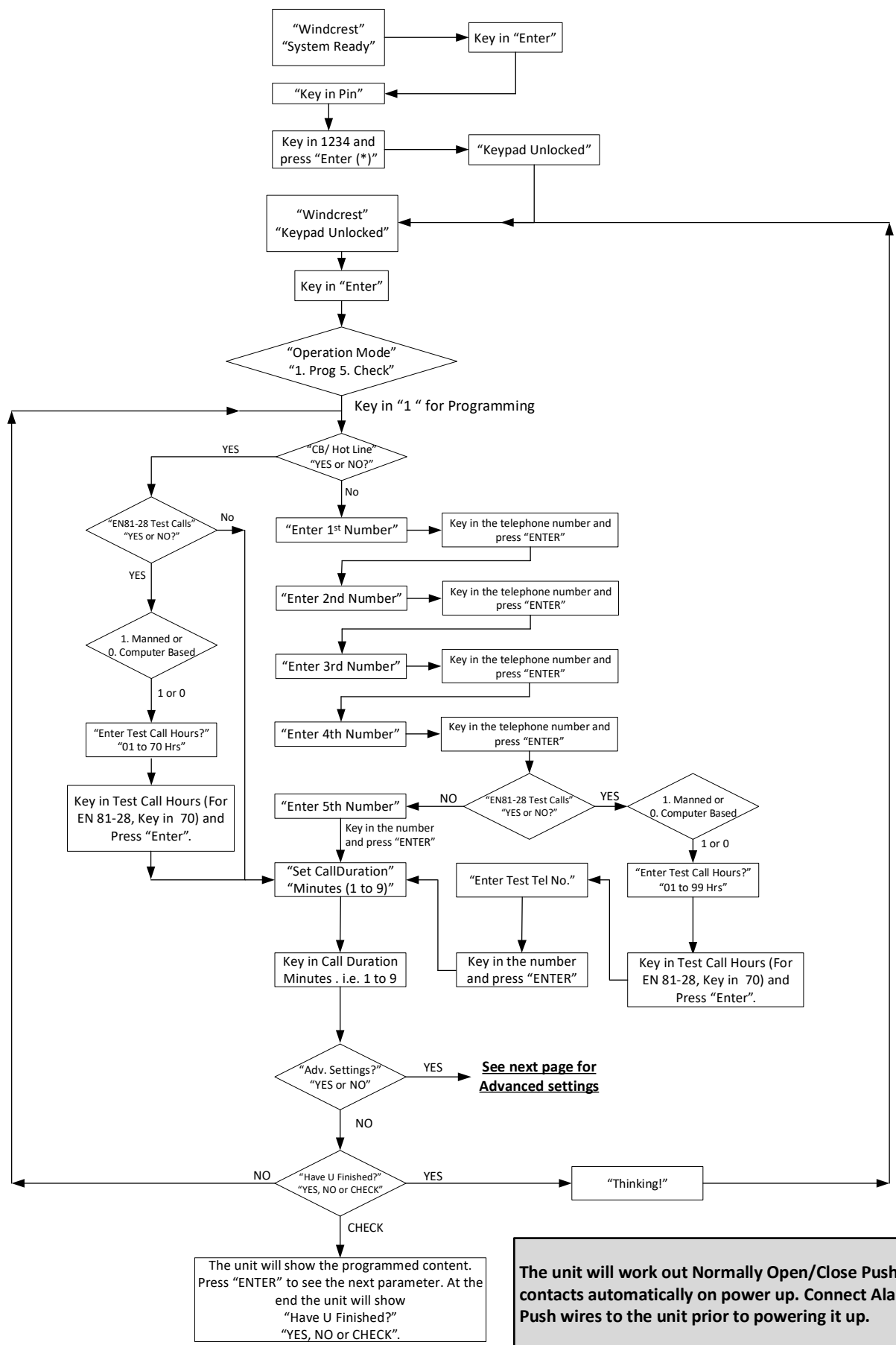

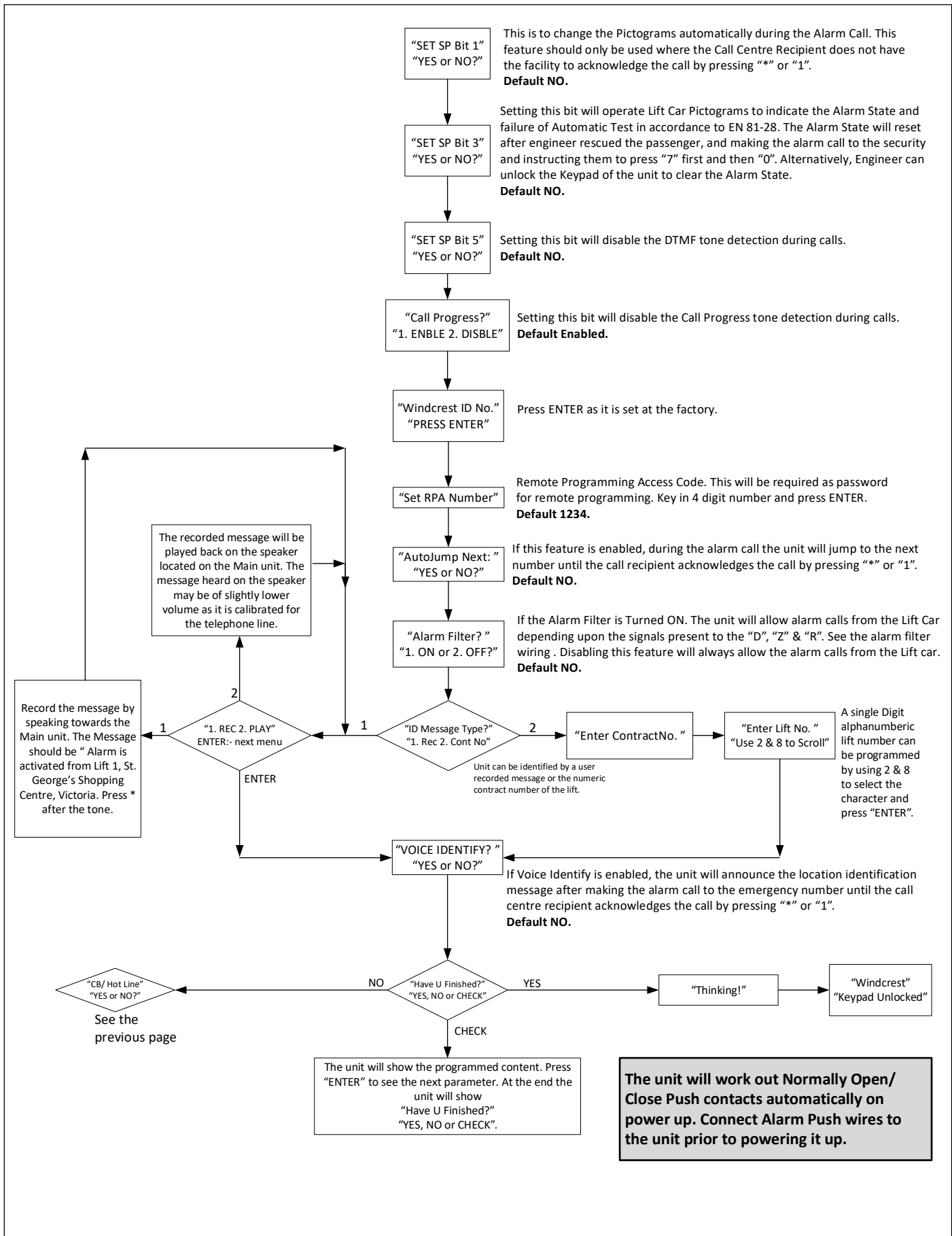

**The unit will work out Normally Open/ Close Push contacts automatically on power up. Connect Alarm Push wires to the unit prior to powering it up.**

## Remote Programming

The system can be remotely programmed by calling the telephone number where the unit is connected.

Follow the steps below:-

- 1) Call the telephone number of the unit.
- 2) Once the unit answers the call, wait for 5 seconds after the unit completes all the automated announcements.
- 3) Key in \*RPA NO# on the telephone handset. For example the default RPA no. is 1234. therefore key in \*1234#. If the RPA is accepted, the unit will respond with two beeps. If the RPA identified by the unit is incorrect, the unit will give several beeps for warning.

Once the RPA is accepted by the unit, key in the strings on the telephone handset to program the corresponding parameter. At the end of each string, the unit will announce the complete string to confirm the programmed parameter in the format "Beep"- "Parameter Digits"- "Beep" -"Value"- "Beep".

### Programming strings:-

|                      |              |
|----------------------|--------------|
| 1st Telephone Number | *11#Number## |
| 2nd Telephone Number | *12#Number## |
| 3rd Telephone Number | *13#Number## |
| 4th Telephone Number | *14#Number## |
| 5th Telephone Number | *15#Number## |
| Contract Number      | *16#Number## |

|                   |      |   |
|-------------------|------|---|
| Windcrest ID Code | *17# | Unit will announce the programmed ID Code |
|-------------------|------|---|

|  |          |   |
|--|----------|---|
| Test Calls   | *20#N##  | N = 0 to Turn OFF<br>N = 1 to Turn ON.  |
| Auto Jump  | *21#N##  | N = 0 to Turn OFF<br>N = 1 to Turn ON   |
| SP BIT 1   | *22#N##  | N = 0 to Turn OFF<br>N = 1 to Turn ON   |
| HOT LINE<br>(Automatic dialling by telephone line) | *23#N##  | N = 0 to Turn OFF<br>N = 1 to Turn ON   |
| Voice ID   | *24#N##  | N = 0 to Turn OFF<br>N = 1 to Turn ON.  |
| Voice ID   | *25#N##  | N = 0 for 3 seconds Trigger Delay<br>N = 1 for Instant Trigger                              |
| Identification Message                             | *26#N##  | N = 0 for Contract Number<br>N = 1 for User Recorded Msg.                                   |
| SP BIT 3   | *27#N##  | N = 0 to Turn OFF<br>N = 1 to Turn ON   |
| Test Call Type                                     | *28#N##  | N = 0 for Computer Based Test calls<br>N = 1 for Manned Test Calls                          |
| Test Call Type                                     | *29#N##  | N = 0 for Call Progress Tone Disabled<br>N = 1 for Call Progress Tone Enabled               |
| Call Duration                                      | *30#N##  | N = 1 to 9  |
| Test Call Frequency (Hrs)                          | *40#NN## | NN = 01 to 99 Hours   |
| Lift Number  | *41#NN## | NN = 00 , 01 , 02 , 03 ,04 ,05 , 06, 07, 08, 09,<br>For Alphabets<br>A=10, B = 11, ....Z=35 |
| Alarm Filter                                       | *46#N##  | N = 0 to Disable<br>N = 1 to Enable   |

To end the Programming \*00#. Unit will give two beeps.

Following can be applied to check the programmed parameter.

\*PARAMETER\*. For Example. To find out the 1<sup>st</sup> programmed number Key in \*11\* and the unit will announce the 1<sup>st</sup> telephone number in the format BEEP-ONE ONE-BEEP-1<sup>st</sup> Programmed Number-BEEP.



All AVCOM Speakers have unique address. This address is set by the Dip Switch on the back of the each speaker box. Following are the arrangements for the Dip Switch for the different speaker box.

Note: X – Do Not Care

|                            | 1   | 2   | 3   | 4   | 5   | 6 |
|----------------------------|-----|-----|-----|-----|-----|---|
| Car Speaker                | ON  | Off | Off | Off | Off | X |
| Top Of Car Speaker         | Off | ON  | Off | Off | Off | X |
| Pit Speaker                | ON  | ON  | Off | Off | Off | X |
| MRL Speaker (For EN4 & FF) | Off | Off | ON  | Off | Off | X |

2COP Speaker This address is special and to be set at factory only.

FF Top Landing (EN3/EN1 StandAlone FF) This address is special and to be set at factory only.

Fire Fighting Main Landing This address is special and to be set at factory only.

| Evacuation Landing Speaker | 1   | 2   | 3   | 4   | 5   | 6 |
|----------------------------|-----|-----|-----|-----|-----|---|
| Landing 1                  | ON  | Off | Off | Off | Off | X |
| Landing 2                  | Off | ON  | Off | Off | Off | X |
| Landing 3                  | ON  | ON  | Off | Off | Off | X |
| Landing 4                  | Off | Off | ON  | Off | Off | X |
| Landing 5                  | ON  | Off | ON  | Off | Off | X |
| Landing 6                  | Off | ON  | ON  | Off | Off | X |
| Landing 7                  | ON  | ON  | ON  | Off | Off | X |
| Landing 8                  | Off | Off | Off | ON  | Off | X |
| Landing 9                  | ON  | Off | Off | ON  | Off | X |
| Landing 10                 | Off | ON  | Off | ON  | Off | X |
| Landing 11                 | ON  | ON  | Off | ON  | Off | X |
| Landing 12                 | Off | Off | ON  | ON  | Off | X |
| Landing 13                 | ON  | Off | ON  | ON  | Off | X |
| Landing 14                 | Off | ON  | ON  | ON  | Off | X |
| Landing 15                 | ON  | ON  | ON  | ON  | Off | X |
| Landing 16                 | Off | Off | Off | Off | ON  | X |
| Landing 17                 | ON  | Off | Off | Off | ON  | X |
| Landing 18                 | Off | ON  | Off | Off | ON  | X |
| Landing 19                 | ON  | ON  | Off | Off | ON  | X |
| Landing 20                 | Off | Off | ON  | Off | ON  | X |
| Landing 21                 | ON  | Off | ON  | Off | ON  | X |
| Landing 22                 | Off | ON  | ON  | Off | ON  | X |
| Landing 23                 | ON  | ON  | ON  | Off | ON  | X |
| Landing 24                 | Off | Off | Off | ON  | ON  | X |
| Landing 25                 | ON  | Off | Off | ON  | ON  | X |
| Landing 26                 | Off | ON  | Off | ON  | ON  | X |
| Landing 27                 | ON  | ON  | Off | ON  | ON  | X |
| Landing 28                 | Off | Off | ON  | ON  | ON  | X |
| Landing 29                 | ON  | Off | ON  | ON  | ON  | X |
| Landing 30                 | Off | ON  | ON  | ON  | ON  | X |
| Landing 31                 | ON  | ON  | ON  | ON  | ON  | X |