





Cable description	 Single core wire	 Multicore cable	 or  Cable used in special cases only
-------------------	--	---	---

Motor Room
(This area represents the Motor Room)

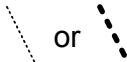

Landing
(Everything here is outside the lift, but near the lift door on the wall)

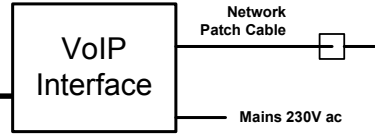
Top of Lift Car
(Everything here is placed on the top of lift car)

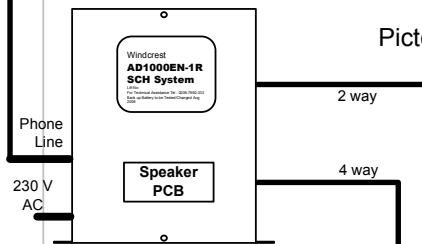

Lift Car
(Everything here is placed in the Lift Car, or in the COP)

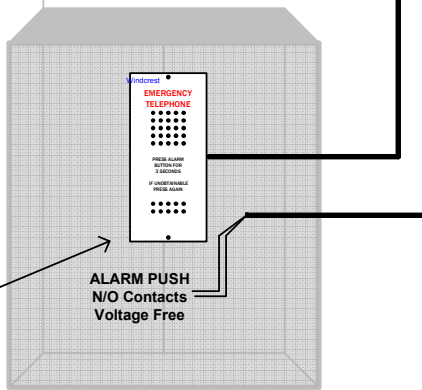





Lift Pit
(Everything here is placed in the lift pit, or in the shaft)

NOTE:

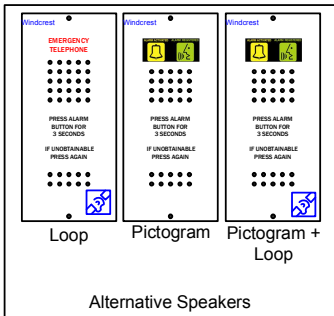
- 1) All cables used for audio connection should be screened & twisted.
- 2) Number of wires from CAR speaker to main control unit may vary depending on the type of CAR speaker.
- 3) CAR speaker with Pictogram, Induction Loop, etc also available.

Other options for CAR speaker

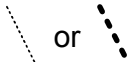

Cable description	 Single core wire	 Multicore cable	 or  Cable used in special cases only
-------------------	--	---	---

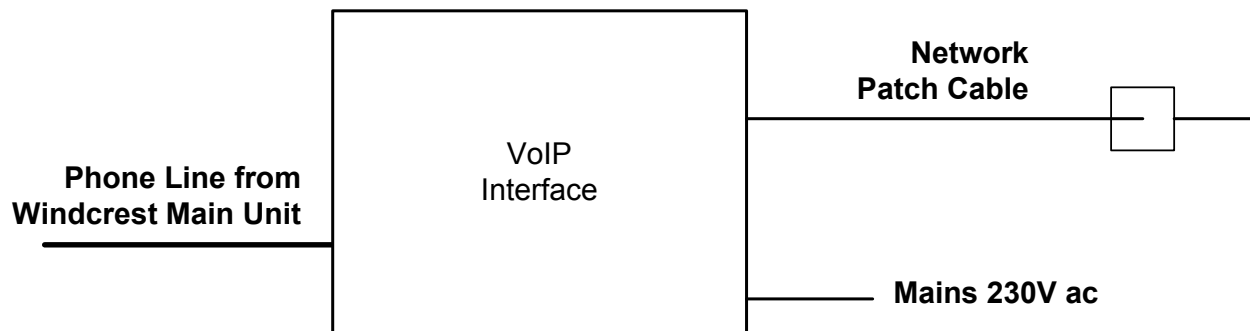

Operation

To make a phone or extension number call:

- Dial the number directly and wait for 4 seconds (Default “No Key Entry Timeout”). Or
- Dial the number directly, and press # (assuming that “Use # as dial key” is selected in web configuration).

Examples:





To dial another extension on the same proxy, such as 1008, simply pick up the attached phone, dial 1008 and then press the # or wait for 4 seconds.

To dial a PSTN number such as 6266667890, you might need to enter in some prefix number followed by the phone number. Please check with your VoIP service provider to get the information. If

Specification of unit

- Supports SIP 2.0(RFC 3261), TCP/UDP/IP, RTP/RTCP, HTTP, ICMP, ARP/RARP, DNS, DHCP (both client and server), NTP, PPPoE, STUN, TFTP, etc.
- Powerful digital signal processing (DSP) to ensure superb audio quality; advanced adaptive jitter control and packet loss concealment technology
- Support various codecs including G.711 (PCM a-law and u-law), G.723.1 (5.3K/6.3K), G.726 (32K), G.729A and iLBC.
- Support Caller ID/name display or block, Call waiting caller ID, Hold, Call Waiting/Flash, Call Transfer, 3-way conference (on Rev. 2.0), Call Forward, in-band and out-of-band DTMF, etc.
- Support fax pass through (for PCMU and PCMA) and T.38 FoIP (Fax over IP)
- Support Silence Suppression, VAD (Voice Activity Detection), CNG (Comfort Noise Generation), Line Echo Cancellation (G.168), and AGC (Automatic Gain Control)
- Support standard encryption and authentication (DIGEST using MD5 and MD5-sess)
- Support for Layer 2 (802.1Q VLAN, 802.1p) and Layer 3 QoS (ToS, DiffServ, MPLS)
- Support automated NAT traversal without manual manipulation of firewall/NAT
- Support device configuration via built-in IVR, Web browser or encrypted configuration files through TFTP or HTTP server
- Support firmware upgrade via TFTP or HTTP
- Support SIP Session Timer
- Support Syslog (on Rev.2.0)

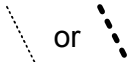
<i>Windcrest</i>	Part No.: VoIP	
	01/08/2010	Page: 2

Cable description	 Single core wire	 Multicore cable	 or  Cable used in special cases only
-------------------	--	---	---

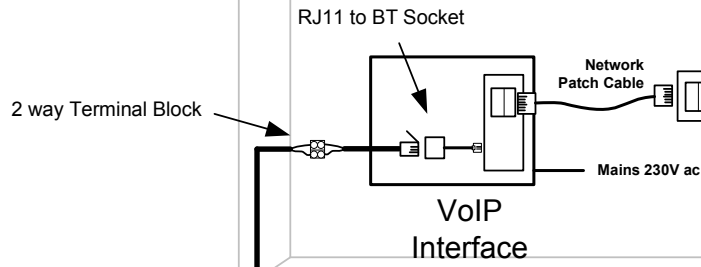

NOTE:

- 1) All cables used for audio connection should be screened & twisted.
- 2) Number of wires from CAR speaker to main control unit may vary depending on the type of CAR speaker.
- 3) CAR speaker with Pictogram, Induction Loop, etc also available.

