

## Introduction

This wiring harness allows you to connect the Windcrest Unit to a KONE lift with a KRM Communication system.

The following procedures need to be carried out to minimise the installation time on site:-

1. Switch OFF Mains and disconnect the Backup batteries, sounder and BT phone line and then anOpen the Connection Box on top of the lift car.
2. Once the top of the car box is Opened, Identify that the lift communication system you are working on by looking for a for a pcb which looks like the drawing on page 2 of this document.
3. Assuming you have confirmed that the lift car has the correct version of the communication equipment, ie a KRM system you can proceed.
4. Open the Car Operating Panel, and install the Microphone, and the Speaker in the moulding. Use the rubber gasket over the speaker to improve the sound quality and volume.
5. Push the cable of the Microphone and Speaker through to the top of the lift car and connect to the Windcrest Speaker box interface.
6. Unplug the 14 way Connector X12 and attach the wires necessary as defined in the drawing on page 3 of this document.
7. Once connected, recheck the wiring and then plug in the back up battery, and switch ON the Mains. & Play” Harness.
8. Programme the Windcrest unit in the usual way and carry out the testes to confirm all is working correctly.
9. Finally, during installation you may trigger the Kone communication equipment which can be reset by unplugging connector XS2 for 5 seconds and then re-plugging it back.

**KONE KRM Wiring**

Drawing: P&P Kone KRM 1/5

*Windcrest*

Tel: 0208 795 0333  
Fax: 0208 795 0444

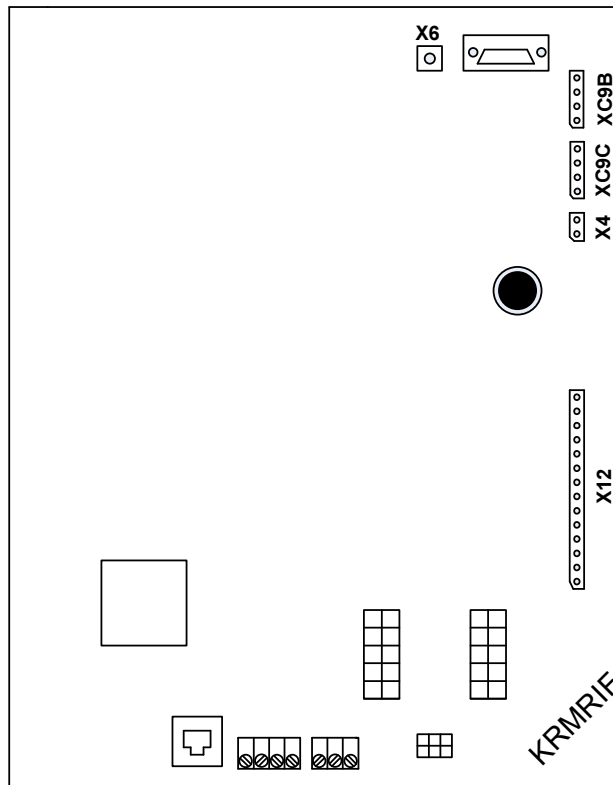

KONE KRM Existing Factory Arrangement in the Top of Car  
 Connection Box (Kone Dg No.812301E24)

Drawing: P&P Kone KRM 2/5

*Winderest*

Tel: 0208 795 0333  
 Fax: 0208 795 0444

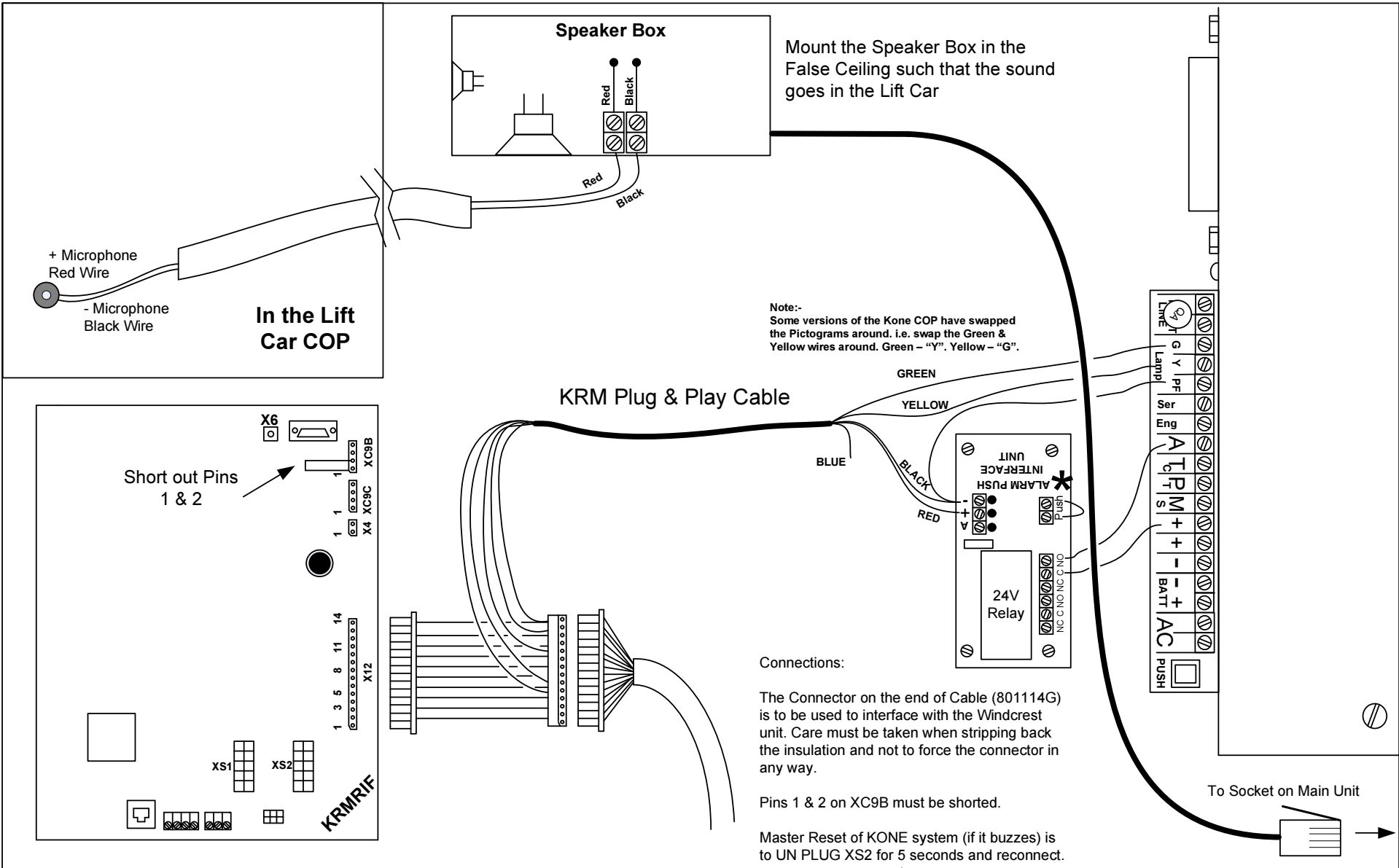

**KONE KRM Plug & Play Cable Top of Car Connection**  
(Kone Dg No.812301E24)

Drawing: P&P KoneKRM 3/5

*Windcrest*

Tel: 0208 795 0333

Fax: 0208 795 0444

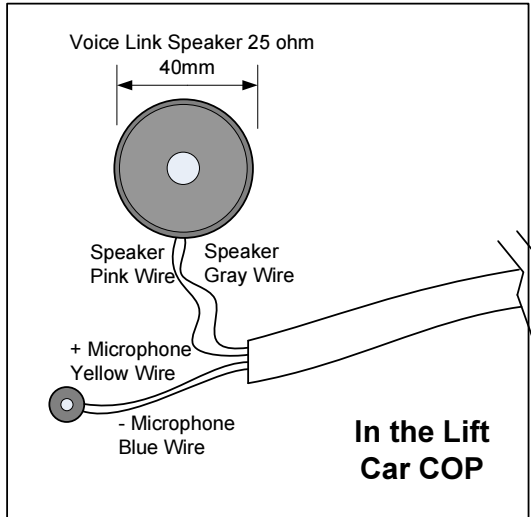

Mount the Speaker Box in the False Ceiling such that the sound goes in the Lift Car

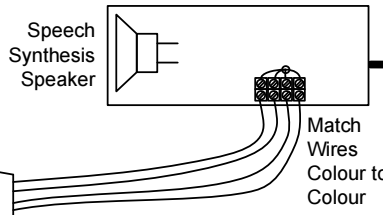

Note:-  
Some versions of the Kone COP have swapped the Pictograms around. i.e. swap the Green & Yellow wires around. Green - "Y". Yellow - "G".

**KRM Plug & Play Cable**

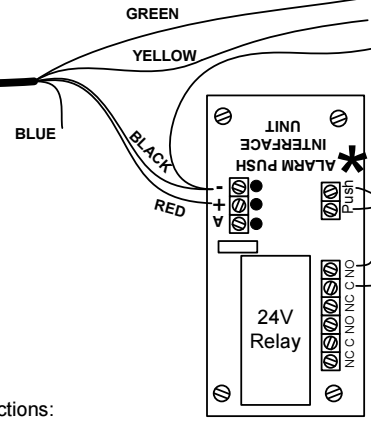
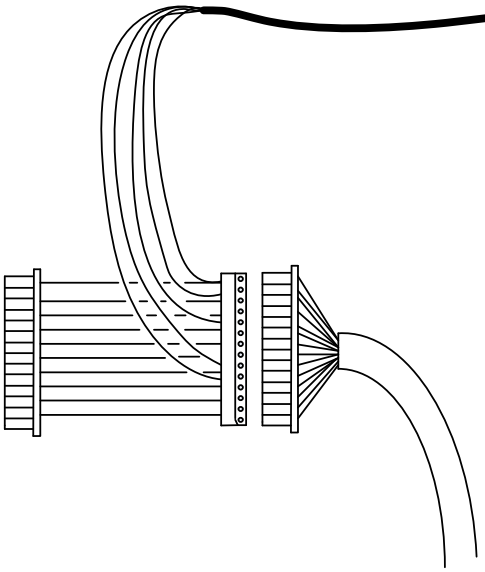
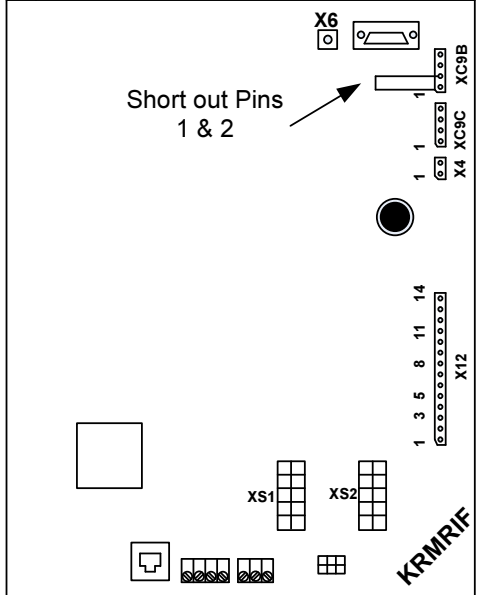

**Connections:**

The Connector on the end of Cable (801114G) is to be used to interface with the Windcrest unit. Care must be taken when stripping back the insulation and not to force the connector in any way.

Pins 1 & 2 on XC9B must be shorted.

Master Reset of KONE system (if it buzzes) is to UN PLUG XS2 for 5 seconds and reconnect.

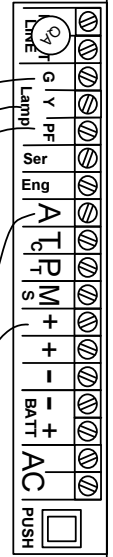

To Socket on Main Unit

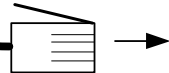

**KONE KRM Plug & Play Cable Top of Car Connection**  
(Kone Dg No.812301E24)

Drawing: P&P KoneKRM 4/5

*Windcrest*

Tel: 0208 795 0333  
Fax: 0208 795 0444

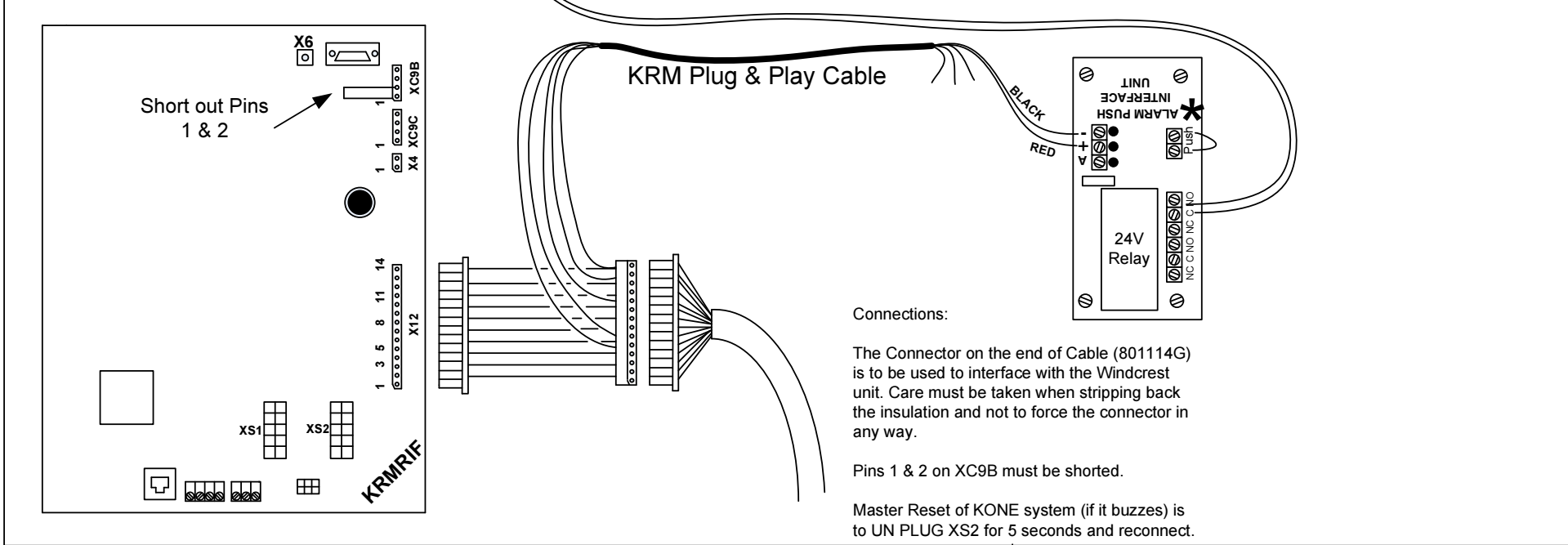
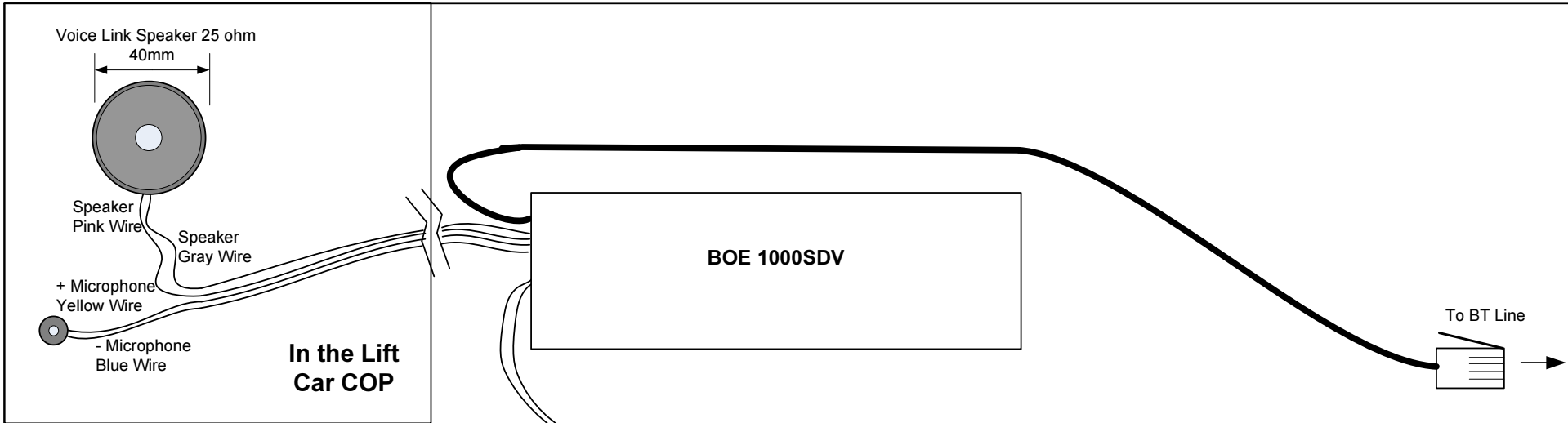

**KONE KRM Plug & Play Cable Top of Car Connection for a BOE1000 System (Kone Dg No.812301E24)**

Drawing: P&P KoneKRM 5/5

*Windcrest*

Tel: 0208 795 0333  
Fax: 0208 795 0444